

HDP 15 Offshore injection pump

Hammelmann offer extremely compact fluid injection pump units for deployment on offshore platforms and FPSO's.



Recommendations and standards

Machine directive 2006/42/EC
ATEX 94/9/EC
API 674 (with exceptions)

Other customer specified standards, i.e.

NORSOK M501
NORSOK M650
NACE MR 0175



TA-Luft (Clean Air) certified to VDI 2440

In the Zero Emission design the pumped fluid is hermetically sealed within the pump preventing leakage to atmosphere during operation.



The bellow system is gastight.

Features

- Hermetically sealed pump
- Continuous monitoring of plunger seals
- Flow control achieved with frequency converter
- Flow turndown ratio 1:10
- Operation with flooded suction possible
- Splash lubricated crank section
- Low pulsation due to triplex design
- High volumetric and mechanic efficiency
- Discharge connection M 48 x 2 female
- Suction connection DN50 PN16 acc. to DIN standard or 2" ANSI B16.5 #150 RF
- Other technical options available upon request

Performance data, HDP 15 with adjustable gear (Selection)

Adjustable gear	5,000 psi	345 bar	10,000 psi	690 bar	15,000 psi	1035 bar
Plunger diameter	D 17,5		D 12		D 10	
Flow rate	2.6 gpm	10 l/min	1.2 gpm	4,8 l/min	0.85 gpm	3,3 l/min
Crank speed	480 rpm	480 rpm	500 rpm	500 rpm	500 rpm	500 rpm
Power rating	15 hp	11 kW	15 hp	11 kW	15 hp	11 kW
Motor speed	1750 rpm	1450 rpm	1750 rpm	1450 rpm	1750 rpm	1450 rpm

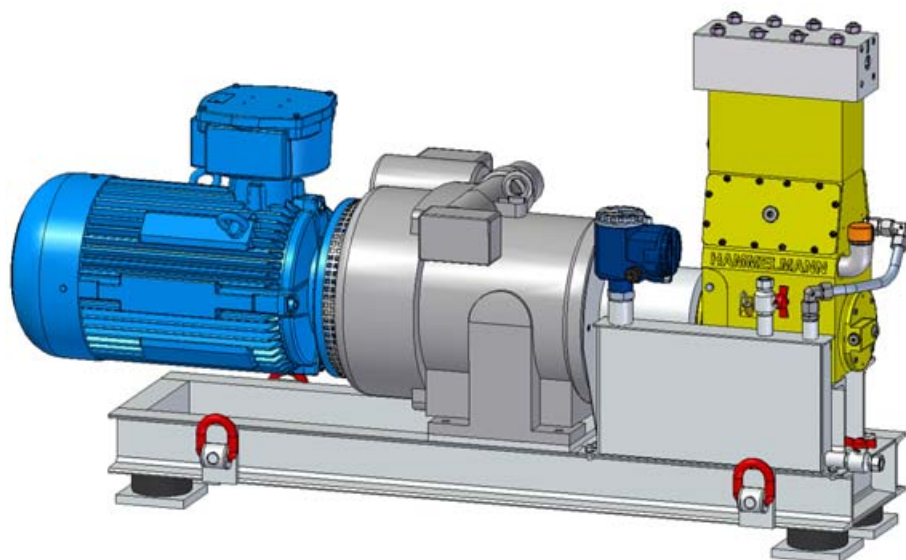

Manual or automatic flow control via adjustable gear.

Stationary unit with electric motor

Length: 1550 mm
Width: 535 mm
Height: 885 mm
Weight: 480 kg
at 11 kW



Performance data, HDP 15 with frequency converter (Selection)

Frequency converter	5,000 psi	345 bar	10,000 psi	690 bar	15,000 psi	1035 bar
Plunger diameter	D 17,5		D 15		D 12	
Flow rate	2.6 gpm	10 l/min	1.5 gpm	6,0 l/min	0.9 gpm	3,5 l/min
Crank speed	480 rpm	480 rpm	400 rpm	400 rpm	370 rpm	370 rpm
Power rating	15 hp	11 kW	15 hp	11 kW	15 hp	11 kW
Motor speed	1750 rpm	1450 rpm	1750 rpm	1450 rpm	1750 rpm	1450 rpm

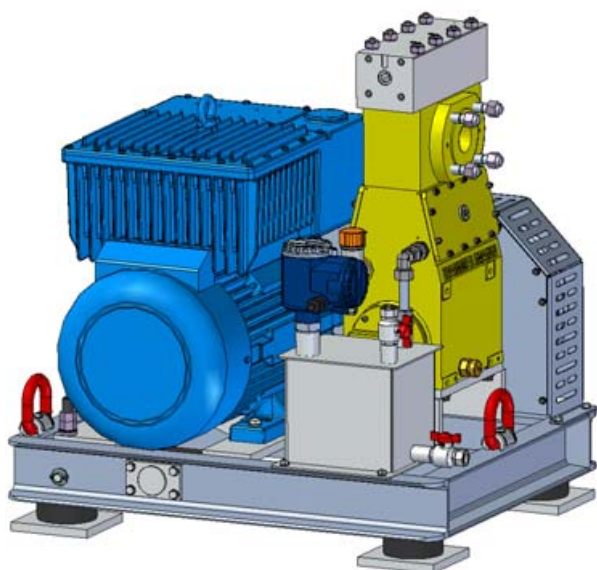

Automatic flow control via frequency converter (integrated in motor housing).

Stationary unit with electric motor

Length: 800 mm
Width: 693 mm
Height: 845 mm
Weight: 480 kg
at 11 kW



Hammelmann
Maschinenfabrik GmbH

Postfach 3309 • D-59282 Oelde
Zum Sundern 13-21 • Germany
eMail: pp@hammelmann.de • Internet: www.process-pumps.de

Telefon (+49) 25 22 76-0
Telefax (+49) 25 22 76-444

HAMMELMANN®