

# HDP 250 High Pressure Pump series

## Design criteria

Hammelmann high pressure pumps are built to operate at the continuous maximum duty stated in the performance parameters. Just compare the crankshaft speed, average plunger speed, plunger diameter and power rating.

### High pressure pump

Weight: approx. 1070 kg

Energy efficient →

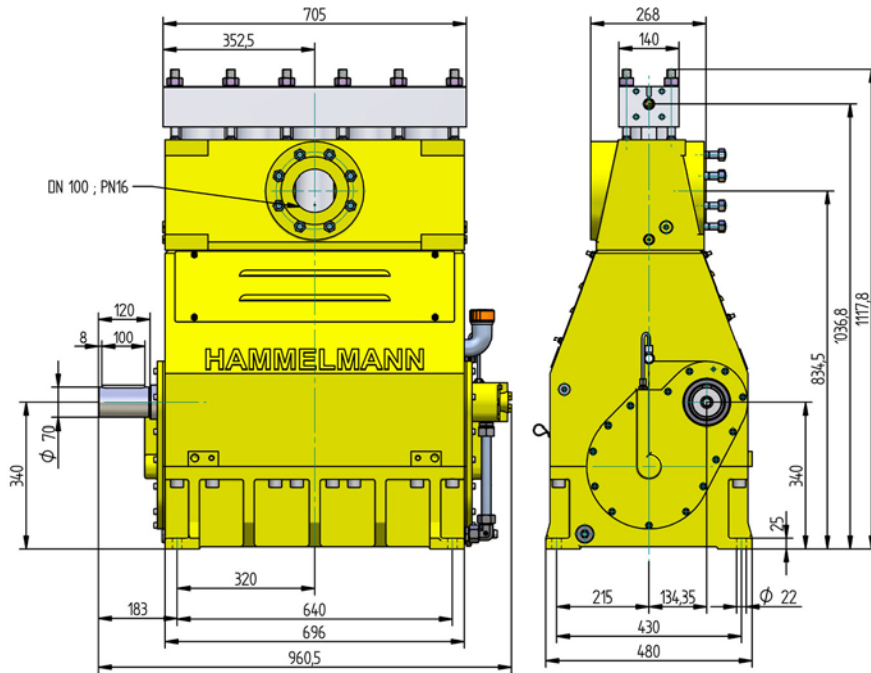

### Features

- Power ratings up to 250 kW
- Vertical 5 cylinder design
- Wide variety of complementary ancillaries

### Quality and reliability

- Stainless steel pump head free of alternating stress
- Cross head piston bellows seal
- Choice of application specific seal assemblies
- Solid ceramic or tungsten carbide plungers
- Choice of bronze or stainless steel suction chamber
- Crank section calculation by 'Finite element method' ensures long working life under continuous load
- Crankshaft supported by 3 bearings and incorporating twin helical speed reducing gears
- Pressurised oil lubrication system with oil cooler/filter

### Stationary unit with electric motor

Length: 2578 mm  
Width: 1290 mm  
Height: 1440 mm  
Weight: approx. 3200 kg at 250 kW

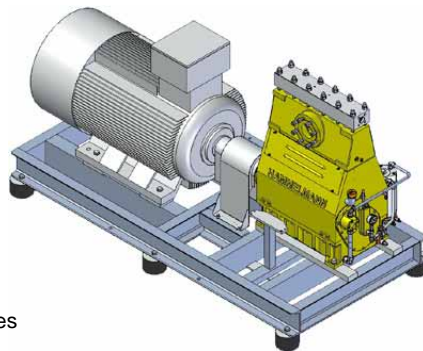

Main dimensions without accessories such as suction line, pressure regulator etc. All shown as right side drive. Detailed dimensional drawings and weights available on request.

### Stationary unit with diesel engine

Length: 2630 mm  
Width: 1570 mm  
Height: 2085 mm  
Weight: approx. 4150 kg at 280 kW with full fuel tank

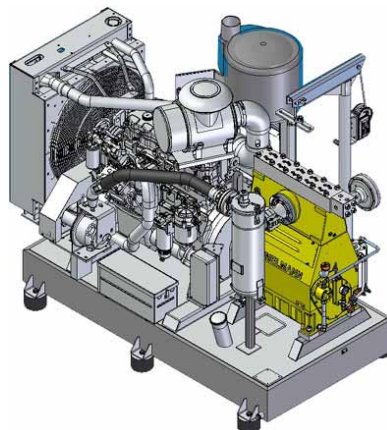

**HAMMELMANN**®

# Technical data, series HDP 250

## Performance parameters (Standard design)

**Note: Actual flow rates for water as pumped medium (volumetric efficiency has already been taken into account).**

HDP	Q [l/min]	Required power rating [kW]					D	r.p.m.			
		110	132	160	200	250		n 1	n 2		
		Operating pressure [bar]									
254	33 / 31* 40 / 37* 48 / 44*	1800 1500	2250* 1800 1500	2750* 2250* 1800	3000* 2850* 2350*	3000*	17,5	1500 1500/1800 1800/2150	390 465 555		
	44 / 40* 52 / 48* 63 / 57*	1350	1650 1350	2100* 1650 1350	2600* 2150* 1700	2600*		1500 1500/1800 1800/2150	390 465 555		
253	67 80 96			1250 1600 1650	1600 1300 1650	1650 1350	25	1500 1500/1800 1800/2150	390 465 555		
	252	97 116 139	610 510 420	730 610 510	890 740 620	1100 920 770		1160 1150 960	30	1500 1500/1800 1800/2150	390 465 555
		132 158 189	450 370 310	540 450 370	650 540 450	810 680 560		850 850 710		35	1500 1500/1800 1800/2150
174 208 249		340 280 240	410 340 280	500 410 340	620 520 430	650 650 540	40	1500 1500/1800 1800/2150			390 465 555
222 266 319		270 220 190	320 270 220	390 330 270	490 410 340	510 510 430		45	1500 1500/1800 1800/2150		390 465 555
277 332 398		220 180 150	260 220 180	320 260 220	400 330 270	420 410 340			50	1500 1500/1800 1800/2150	390 465 555
336 400 479		180 150 120	210 180 150	260 220 180	330 270 230	340 340 280	55			1500 1500/1800 1800/2150	390 465 555
395 473 567		150 120 100	180 150 120	220 180 150	270 230 190	290 280 240		60		1500 1500/1800 1800/2150	390 465 555
538 644 766		110 90 70	130 110 90	160 130 110	200 170 140	210 210 170			70	1500 1500/1800 1800/2150	390 465 555

\*Ultra high pressure

Conversion table

Rating 1 kW = 1,34 HP  
Op. Pressure 1 bar = 14,5 psi  
Flow rate 1 l = 0,264 US gallon  
1 l = 0,22 Imp. gallon

D = Piston/Plunger dia. [mm]

n1 = Motor/Engine r.p.m.

n2 = Crankshaft

HDP	Seal **	Sealing system
254	Dynamic	Tungsten carbide plunger & bushing
	Packing	Special ceramic plunger *** / packing
253	Dynamic	Ceramic plunger / bronze bushing
	Packing	Ceramic plunger / packing
252	Dynamic	Ceramic plunger / bronze bushing
	Packing	Ceramik plunger / packing

\*\* The dynamic high pressure sealing extends the advantages of the labyrinth design with further increased efficiency.

\*\*\* Special ceramic plungers up to max. 2600 bar.

- Rod force: 82 kN
- Stroke: 75 mm
- Mean piston speed at n<sub>2</sub>  
390 r.p.m. = 0,97 m/sec  
465 r.p.m. = 1,16 m/sec  
555 r.p.m. = 1,39 m/sec

Typical high pressure pump units



- Stationary diesel unit in BDF-Container with workshop



- Stationary electric unit



- Electric unit in container

**Energy efficient**

Hammelmann plunger pumps convert 93 to 98 % of the shaft power to hydraulic energy.

Hammelmann Maschinenfabrik GmbH

Postfach 3309 • D-59282 Oelde Telefon (0 25 22) 76-0  
Zum Sundern 13-21 • Germany Telefax (0 25 22) 76-444  
eMail: mail@hammelmann.de • Internet: www.hammelmann.com

**HAMMELMANN®**