

HDP 20 High Pressure Pump Series

Design criteria

Hammelmann high pressure pumps are built to operate at the continuous maximum duty stated in the performance parameters. Just compare the crank shaft speed, average plunger speed, plunger diameter and power rating.

High Pressure Pump

Weight: 95 kg

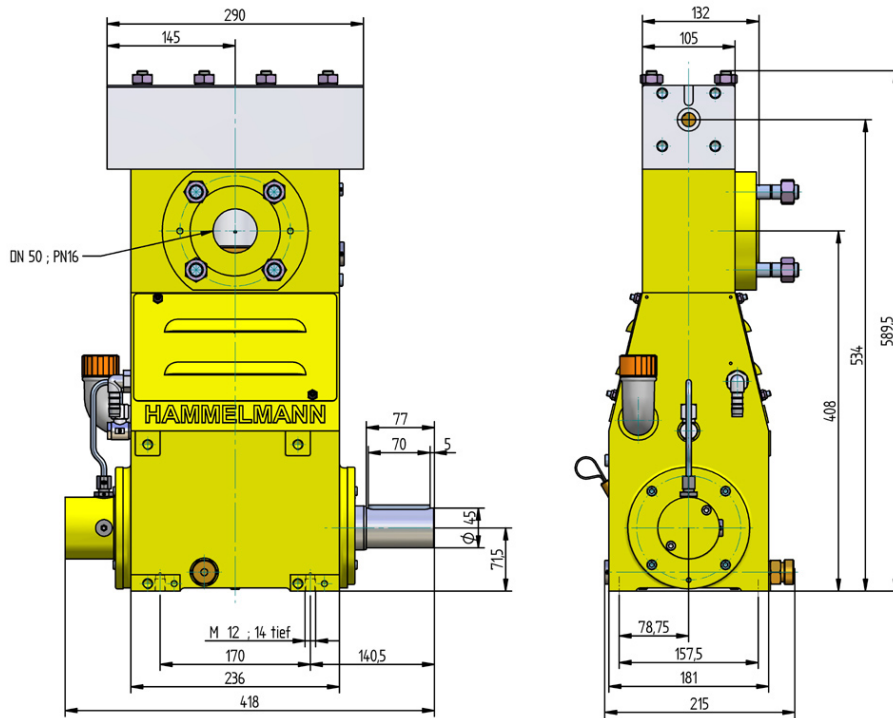

Features

- Power ratings up to 18,5 kW
- Vertical 3 cylinder design
- Wide variety of complementary ancillaries

Quality and reliability

- Stainless steel pump head free of alternating stress
- Bellows form hermetic seal between the suction chamber and crank section
- Choice of application specific seal assemblies
- Solid ceramic or tungsten carbide plungers
- Choice of bronze (standard) or stainless steel suction chamber
- Crank section calculation by 'Finite element method' ensures long working life under continuous load
- Pressurised oil lubrication system

Stationary unit with electric motor

Length: 1000 mm
 Width: 752 mm
 Height: 890 mm
 Weight: approx. 450 kg
 at 22 kW

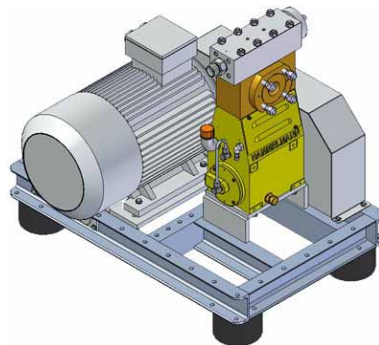

Main dimensions without accessories such as suction line, pressure regulator etc. All shown as right side drive. Detailed dimensional drawings and weights available on request.

HDP 20 series, technical data

Performance parameters (Standard design)

Note: Actual flow rates for water as pumped medium (volumetric efficiency has already been taken into account).

HDP	Q [l/min]	Required power rating [kW]			D	r.p.m.		
		11	15	18,5		n1	n2	
		Operating pressure [bar]						
24	2,2	2200	3000	3500	8	1500/1800/2150		625
	2,7	1850	2500	3100				750
	3,2	1550	2100	2600				900
	3,6	1400	1900	2250	10	1500/1800/2150		625
	4,4	1200	1600	2000				750
	5,4	980	1350	1650				900
23	3,6	1400	1800		10	1500/1800/2150		625
	4,4	1200	1600					750
	5,4	980	1350					900
	5,7	970	1300	1550	12	1500/1800/2150		625
	6,9	820	1100	1350				750
	8,2	690	930	1150				900
22	9	620	850	1000	15	1500/1800/2150		625
	11	530	720	880				750
	12	460	620	730	17,5	1500/1800/2150		625
	15	380	520	640				750
	16	350	480	560	20	1500/1800/2150		625
	20	290	400	490				750
	25	220	300	360	25	1500/1800/2150		625
	31	190	250	310				750
	37	150	210	250	30	1500/1800/2150		625
	45	130	180	220				750
	51	115	150	180	35	1500/1800/2150		625
	62	95	130	160				750
	66	85	120	140	40	1500/1800/2150		625
	82	75	100	120				750
	84	70	95	110	45	1500/1800/2150		625
103	55	75	95	750				

- Rod force: 17,6 kN
- Stroke: 30 mm
- Mean piston speed at n₂

625 r.p.m. = 0,63 m/sec

750 r.p.m. = 0,75 m/sec

900 r.p.m. = 0,90 m/sec

Typical high pressure pump units



- Stationary unit with electric motor



- Stationary electric unit with sound damping cover

Conversion table

Rating 1 kW = 1.34 HP
 Op. pressure 1 bar = 14.5 psi
 Flow rate 1 l = 0.264 US gallon
 1 l = 0.22 Imp. gallon

D = Piston/Plunger dia. [mm]
 n1 = Motor/Engine r.p.m.
 n2 = Crankshaft r.p.m.

HDP	Seal*	Sealing system
24	Dynamic	Tungsten carbide plunger & bushing
	Packing	Special ceramic plunger** / packing
23	Dynamic	Ceramic plunger / bronze bushing
	Packing	Ceramic plunger / packing
22	Dynamic	Ceramic plunger / bronze bushing
	Packing	Ceramik plunger / packing

* The dynamic high pressure sealing extends the advantages of the labyrinth design with further increased efficiency.

** Special ceramic plungers up to max. 2500 bar

Energy efficient →

Hammelmann plunger pumps convert 93 to 98 % of the shaft power to hydraulic energy.

Hammelmann Maschinenfabrik GmbH

Postfach 3309 • D-59282 Oelde
 Zum Sundern 13-21 • Germany
 eMail: mail@hammelmann.de

Telefon (0 25 22) 76-0
 Telefax (0 25 22) 76-444
 Internet: www.hammelmann.com

HAMMELMANN®