

HDP 365 process plunger pumps

Hammelmann process pumps are built to operate at continuous maximum duty. Just compare the crank shaft speed, average plunger speed, plunger diameter and power rating.

High pressure pump

Weight: approx. 3,750 lbs

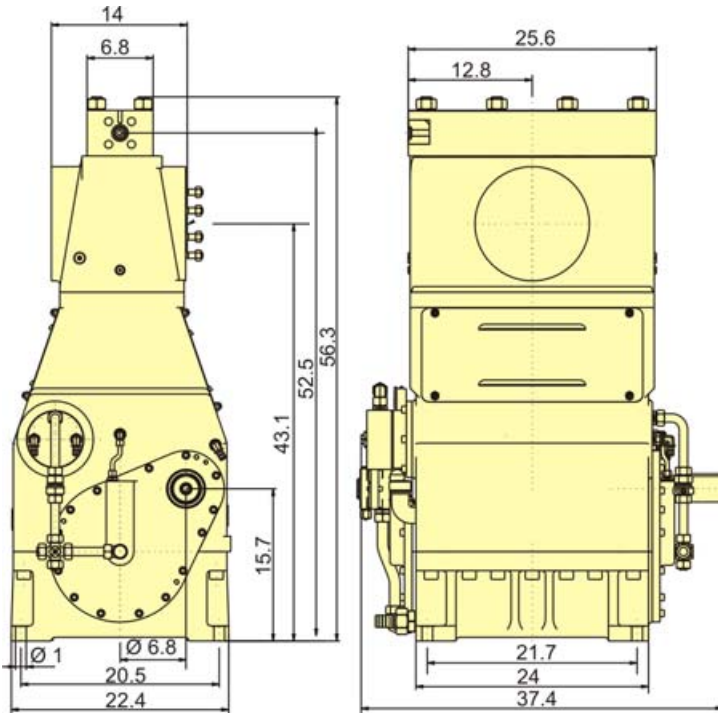

Dimensions: inch

Stationary unit with electric motor

Length: 103 inch
 Width: 53 inch
 Height: 70 inch
 Weight: approx. 8,400 lbs at 400 HP

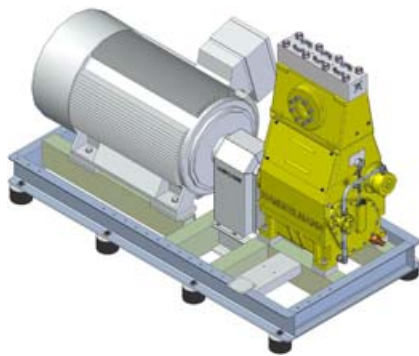

Main dimensions without accessories such as pulsation damper, safety valve etc. Relevant drawings and weights available on request.



TA-Luft (Clean Air) certified to VDI 2440

In the Zero Emission design the pumped fluid is hermetically sealed within the pump preventing leakage to atmosphere during operation.

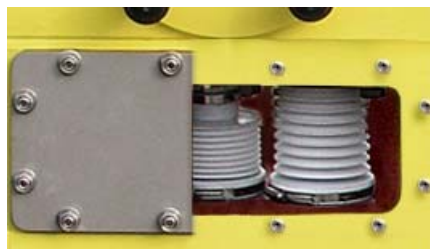

The bellows system is gastight.



Features

- Power ratings up to 400 HP
- Vertical 3 cylinder design
- Wide variety of complementary ancillaries

Quality and reliability

- Crank section calculation by 'Finite element method' ensures long working life under continuous load
- Twin helical integral reduction gear with crankshaft supported by 2 bearings
- Pressurised oil lubrication system incorporating an oil pump and oil cooler/filter unit
- Bellows form hermetic seal between the suction chamber and crank section
- Bronze or stainless steel suction chamber
- Solid ceramic or tungsten carbide plungers
- Stainless steel pump head free of alternating stress
- Choice of performance and pumped medium specific seal and pump head assemblies

HAMMELMANN[®]

HDP 365 series, technical data

Performance parameters

Q [GPM] *	Required power rating [HP]**					D	r.p.m.	
	200	250	300	350	400		n 1	n 2
	Operating pressure [psig]							
7.4	34500	42100	43500			28	1000	230
9.0	28900	34900	43500				1000/1200	275
10.8	23900	29000	36400	43500			1200	325
11.4	23100	28000	34900	43500			1500	340
11.9	22000	26800	30200			35	1000	230
14.3	18400	22300	28000	30200			1000/1200	275
16.9	15400	18700	23300	29100	30200		1200	325
17.7	14800	17800	22300	28000	30200		1500	340

* At pressures over 2000 bar approx. 5% of the flow rate is lost due to the compressibility factor of water

15.6	17000	20600	23100			40	1000	230
18.8	14100	17100	21500	23100			1000/1200	275
22.5	11700	14200	17800	22300	23100		1200	325
23.5	11300	13600	17100	21300	23100		1500	340

20.1	13300	16200	18300			45	1000	230
24.0	11200	13500	16800	18300			1000/1200	275
28.8	9300	11300	14100	17700	18300		1200	325
30.1	8800	10700	13500	16800	18300		1500	340
25.1	10900	13200	14800			50	1000	230
29.9	9000	10900	13600	14800			1000/1200	275
35.9	7500	9100	11500	14200	14800		1200	325
37.5	7300	8700	10900	13600	14800		1500	340
30.6	9000	10900	12200			55	1000	230
36.6	7400	9000	11300	12200			1000/1200	275
43.9	6200	7500	9400	11700	12200		1200	325
45.8	5900	7300	9000	11300	12200		1500	340
36.7	7500	9100	10300			60	1000	230
44.0	6200	7500	9400	10300			1000/1200	275
52.8	5200	6400	7800	9900	10300		1200	325
55.1	4900	6100	7500	9400	10300		1500	340
43.5	6400	7700	8700			65	1000	230
52.2	5400	6400	8100	8700			1000/1200	275
62.6	4400	5400	6700	8400	8700		1200	325
65.3	4200	5100	6400	8100	8700		1500	340
50.5	5500	6700	7500			70	1000	230
60.5	4600	5500	7000	7500			1000/1200	275
72.6	3800	4600	5800	7300	7500		1200	325
75.8	3600	4500	5500	7000	7500		1500	340
58.0	4800	5800	6500			75	1000	230
69.5	3900	4800	6100	6500			1000/1200	275
83.4	3300	4100	5100	6200	6500		1200	325
87.0	3200	3900	4800	6100	6500		1500	340
66.0	4200	5100	5800			80	1000	230
79.0	3500	4200	5400	5800			1000/1200	275
94.8	2900	3500	4400	5500	5800		1200	325
99.0	2800	3300	4200	5400	5800		1500	340

83.5	3300	4100	4500			90	1000	230
100.0	2800	3300	4200	4500			1000/1200	275
120.0	2300	2800	3500	4400	4500		1200	325
125.3	2200	2600	3300	4200	4500		1500	340
103.1	2600	3200	3600			100	1000	230
123.5	2200	2800	3300	3600			1000/1200	275
148.2	1900	2200	2800	3500	3600		1200	325
154.7	1700	2200	2800	3300	3600		1500	340
124.8	2200	2600	3000			110	1000	230
149.4	1700	2200	2800	3000			1000/1200	275
179.3	1500	1900	2300	2900	3000		1200	325
187.2	1400	1700	2200	2800	3000		1500	340
148.5	1900	2200	2500			120	1000	230
177.8	1500	1900	2300	2500			1000/1200	275
213.4	1300	1600	1900	2500			1200	325
222.7	1200	1500	1900	2300	2500		1500	340

- Rod force: 45,000 lbf
- Stroke: 2,95 inch
- Mean piston speed at n₂
 - 230 r.p.m. = 1.87 feet/sec
 - 275 r.p.m. = 2.23 feet/sec
 - 325 r.p.m. = 2.69 feet/sec
 - 340 r.p.m. = 2.79 feet/sec

Pump head in "High Flow" design for piston diameters of 90 mm and above

* GPM = Water as measurement fluid
Flow rates can vary with type of medium

** Electric motor

D = Piston/Plunger dia. [mm]

n1 = Motor r.p.m.

n2 = Crankshaft r.p.m

Conversion table

Rating 1 hp = 0,746 kW

Op.pressure 1 psi = 0,069 bar

Flow rate 1 gpm = 0,227 m³/h

Hammelmann Corp. 600 Progress Road
Dayton, Ohio 45449
eMail: mail@hammelmann.com

Phone (001) 937-859-8777
Fax: (001) 937-859-9188
http://www.hammelmann.com

