

HDP 70 High Pressure Pump Series

Design criteria

Hammelmann high pressure pumps are built to operate at the continuous maximum duty stated in the performance parameters. Just compare the crank shaft speed, average plunger speed, plunger diameter and power rating.

High pressure pump

Weight: approx. 470 lbs

Dimensions: mm

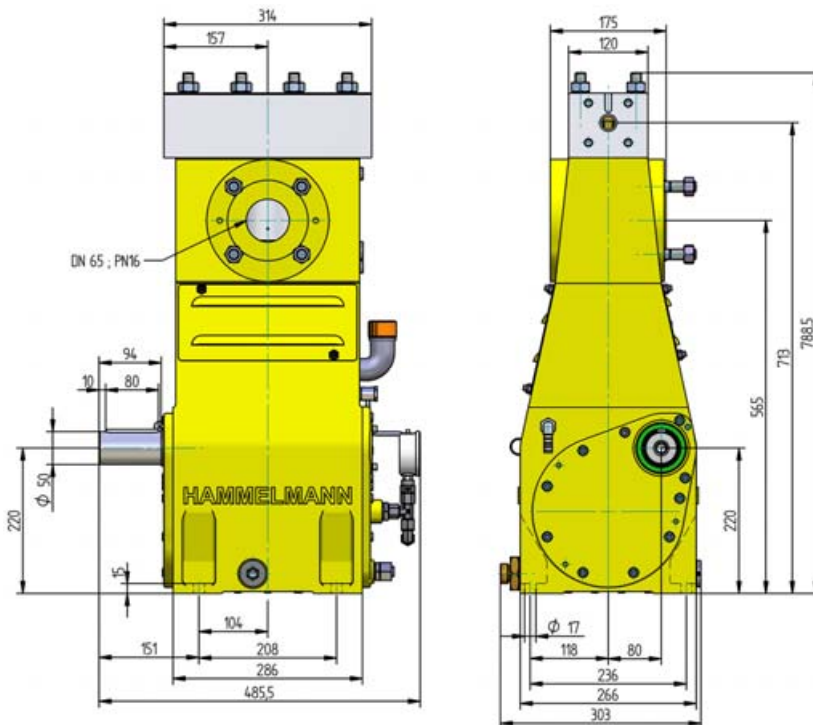

Features

- Power ratings up to 95 HP
- Vertical 3 cylinder design
- Wide variety of complementary ancillaries

Quality and reliability

- Stainless steel pump head free of alternating stress
- Choice of application specific seal assemblies
- Solid ceramic or tungsten carbide plungers
- Choice of bronze (standard) or stainless steel suction chamber
- Crank section calculation by 'Finite element method' ensures long working life under continuous load
- Integral speed reduction gear
- Pressurised oil lubrication system with oil cooler/filter

Stationary unit with electric motor

Length: 59 inch

Width: 28 inch

Height: 43 inch

Weight: approx. 521 lbs
at 100 HP

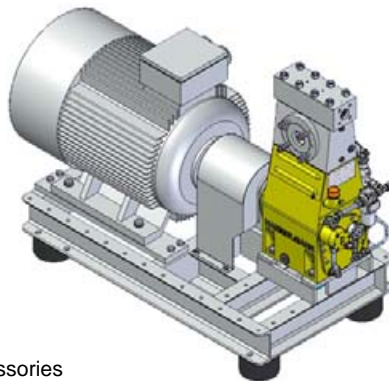

Main dimensions without accessories such as suction line, pressure regulator etc. All shown as right side drive. Detailed dimensional drawings and weights available on request.

HDP 70 series, technical data

Performance parameters

Q (GPM)*	Required power rating [HP]					D	r.p.m.	
	40	50	60	75	95		n 1	n 2
	operating pressure (psig)							
1.8	29000	35500	43500			12	1500	625
2.2	23900	29700	36300	43500			1500/1800	750
2.6	20300	24700	30500	37000	43500		1800/2150	900
2.9	18100	22500	27600	34100		15	1500	625
3.4	15200	18900	23200	28300	34800		1500/1800	750
4.2	12900	16000	18900	23200	29700		1800/2150	900
4.5	13500	16700	20300	24700		17,5	1500	625
5.1	11300	14100	16700	20300	25400		1500/1800	750
6.1	9400	11700	14200	17400	21800		1800/2150	900

* At pressures over 29,000 psi approx. 5% of the flow rate is lost due to the compressibility factor of water

5.5	10300	12800	15200	18900		20	1500	625
6.9	8700	10700	13100	16000	19600		1500/1800	750
6.9	8700	10700	13100	16000	16400	22	1500	625
8.4	7300	8800	10900	13200	16400		1500/1800	750
8.4	7300	9000	10900	13300	13800	24	1500	625
10.0	6100	7500	9100	11300	13800		1500/1800	750
10.0	6200	7700	9300	11300	11700	26	1500	625
11.9	5100	6400	7700	9400	11700		1500/1800	750
13.2	4600	5700	7000	8600		30	1500	625
15.6	3800	4800	5800	7100	8700		1500/1800	750
18.2	3300	4200	5100	6200		35	1500	625
21.4	2800	3500	4200	5200	6400		1500/1800	750
24.0	2600	3200	3900	4800		40	1500	625
28.2	2200	2600	3200	3900	4900		1500/1800	750
30.4	2000	2500	3000	3800		45	1500	625
35.6	1600	2000	2500	3000	3900		1500/1800	750
37.5	1600	1900	2500	3000		50	1500	625
44.1	1300	1600	2000	2500	3000		1500/1800	750
45.4	1300	1600	2000	2500		55	1500	625
53.1	1000	1300	1600	2000	2600		1500/1800	750
64.9**	870	1000	1500	1700	2200		1800/2150	900

** For intermittent operation only

Conversion table

Rating 1 hp = 0,746 kW
Op.pressure 1 psi = 0,069 bar
Flow rate 1 gpm = 0,227 m³/h

D = Piston/Plunger dia. [mm]

n1 = Motor/Engine r.p.m.

n2 = Crankshaft r.p.m.

- Rod force: 9,670 lbf
- Stroke: 1.57 inch
- Mean piston speed at n₂
625 r.p.m. = 3.3 feet/sec
750 r.p.m. = 3.9 feet/sec
900 r.p.m. = 4.7 feet/sec

Typical high pressure pump units



- Stationary unit with electric motor

1' 10"



- Trolley



- Stationary or road going trailer units with sound damping cover
- 10 foot sound damped container versions

Type designations

Sealing system	D	HDP Type
Hydrodynamic with tungsten carbide plungers	12 – 17,5	74
Hydrodynamic with solid ceramic plungers	20 - 55	72
Packed sleeves with solid ceramic plungers	20 - 55	77

Hammelmann Corp. 600 Progress Road
Dayton, Ohio 45449
eMail: mail@hammelmann.com

Phone (001) 937-859-8777
Fax: (001) 937-859-9188
http://www.hammelmann.com

HAMMELMANN