

HDP 40 High Pressure Pump Series

Design criteria

Hammelmann high pressure pumps are built to operate at the continuous maximum duty stated in the performance parameters. Just compare the crank shaft speed, average plunger speed, plunger diameter and power rating.

High pressure pump

Weight: approx. 440 lbs

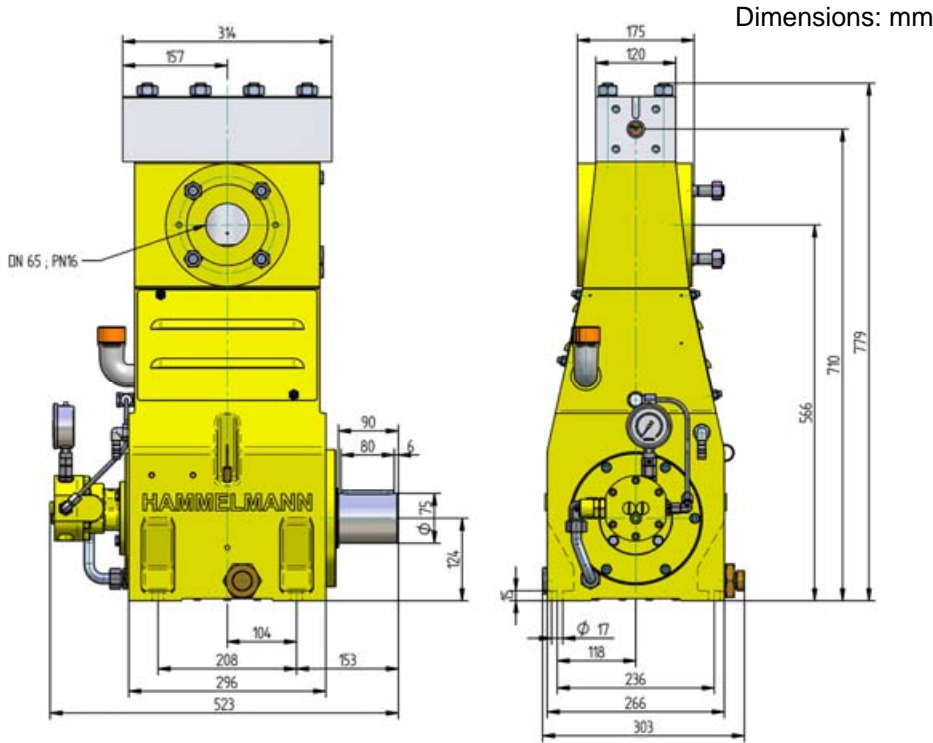

Features

- Power ratings up to 50 HP
- Vertical 3 cylinder design
- Wide variety of complementary ancillaries

Quality and reliability

- Stainless steel pump head free of alternating stress
- Bellows form hermetic seal between the suction chamber and crank section
- Choice of application specific seal assemblies
- Solid ceramic or tungsten carbide plungers
- Choice of bronze (standard) or stainless steel suction chamber
- Crank section calculation by 'Finite element method' ensures long working life under continuous load
- Pressurised oil lubrication system

Stationary unit with electric motor

Length: 43 inch
Width: 32 inch
Height: 43 inch
Weight: approx. 1600 lbs at 40 HP

Main dimensions without accessories such as suction line, pressure regulator etc. All shown as right side drive. Detailed dimensional drawings and weights available on request.

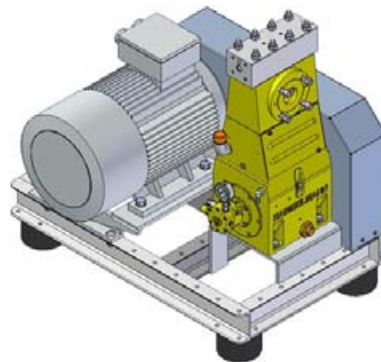

HDP 40 series, technical data

Performance parameters

Q [GPM]*	Required power rating [HP]					D	r.p.m.	
	20	25	30	40	50		n 1	n 2
operating pressure [psig]								
1.5	19600	23900	29700	40600	43500	12	1500 / 1800 / 2150	625
1.7	16000	20300	23900	34100	42100	12		750
1.9	13500	16700	19600	26800	34800	12		900
2.4	12500	15400	18100	24700	31900	15	1500 / 1800 / 2150	625
2.9	10400	12800	15200	21000	25400	15		750
3.4	8700	10700	12800	17400	21800	15		900
3.3	9100	11300	13500	18100	22500	17,5	1500 / 1800 / 2150	625
4.0	7700	9400	11200	15200	18900	17,5		750
4.8	6400	7800	9400	12800	16000	17,5		900

* At pressures over 29,000 psi approx. 5% of the flow rate is lost due to the compressibility factor of water

4.4	7000	8700	10300	14100	17400	20	1500 / 1800 / 2150	625
5.3	5800	7300	8600	11700	14500	20		750
5.3	5800	7100	8600	11600	14200	22		625
6.3	4800	5900	7100	9700	11900	22		750
6.3	4800	5900	7100	9700	12000	24		625
7.7	4100	4900	5900	8100	10000	24		750
7.4	4100	5100	6100	8300	10300	26		625
9.0	3500	4200	5100	7000	86000	26		750
10.0	3000	3800	4500	6200	7700	30		625
11.9	2600	3200	3800	5200	6400	30		750
13.7	2200	2800	3300	4500	5700	35		625
16.4	1900	2300	2800	3800	4600	35		750
18.0	1700	2200	2500	3500	4400	40		625
21.6	1500	1800	2100	2900	3600	40		750
22.7	1400	1700	2000	2800	3300	45		625
27.2	1200	1400	1700	2300	2800	45		750
28.2	1100	1400	1600	2200	2800	50		625
33.8	900	1200	1400	1900	2300	50		750
34.1	900	1200	1300	1800	2300	55		625
41.0	700	900	1100	1500	1900	55		750

Conversion table
 Rating 1 hp = 0,746 kW
 Op.pressure 1 psi = 0,069 bar
 Flow rate 1 gpm = 0,227 m³/h

D = Piston/Plunger dia. [mm]
 n1 = Motor/Engine r.p.m.
 n2 = Crankshaft r.p.m.

Type designations

Sealing system	D	HDP Type
Hydrodynamic with tungsten carbide plungers	12 – 17,5	44
Labyrinth with solid ceramic plungers	20 - 55	42
Packed sleeves with solid ceramic plungers	20 - 55	47

- Rod force: 8,770 lbf
- Stroke: 1.18 inch
- Mean piston speed at n₂
 625 r.p.m. = 2.1 feet/sec
 750 r.p.m. = 2.5 feet/sec
 900 r.p.m. = 3.0 feet/sec

Typical high pressure pump units



- Stationary unit with diesel motor



- Stationary unit with electric motor



- Mobile electric unit with hose reel

Hammelmann Corp. 600 Progress Road
 Dayton, Ohio 45449
 eMail: mail@hammelmann.com

Phone (001) 937-859-8777
 Fax: (001) 937-859-9188
 http://www.hammelmann.com

HAMMELMANN®