

HDP 360 High Pressure Pump Series

Design criteria

Hammelmann high pressure pumps are built to operate at the continuous maximum duty stated in the performance parameters. Just compare the crank shaft speed, average plunger speed, plunger diameter and power rating.

High pressure pump

Weight: approx. 3748 lbs

Dimensions: mm

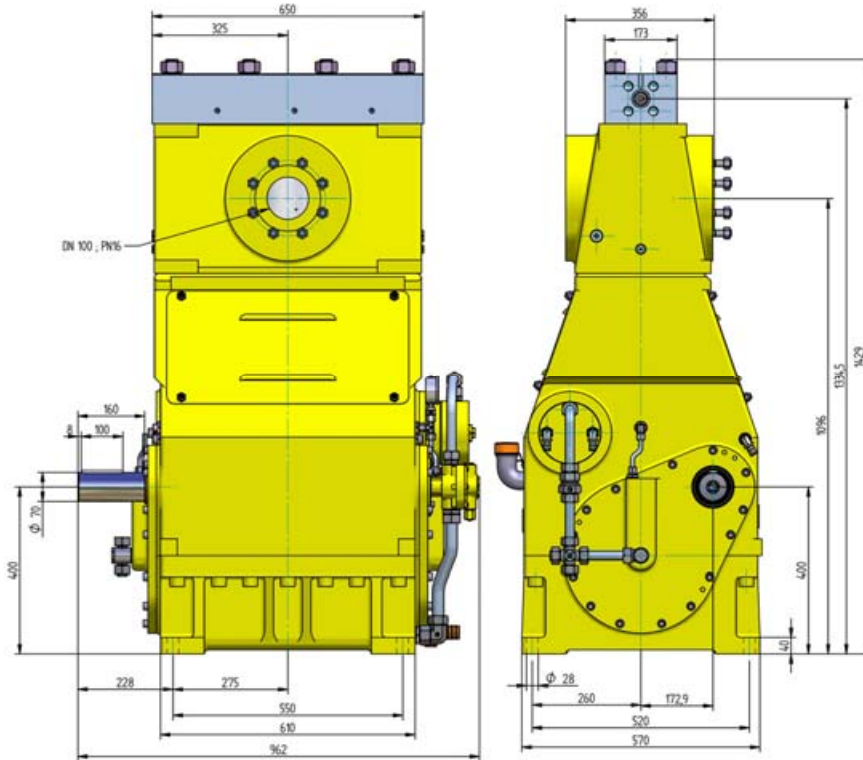

Features

- Power ratings up to 470 HP
- Vertical 3 cylinder design
- Wide variety of complementary ancillaries

Quality and reliability

- Stainless steel pump head free of alternating stress
- Cross head piston bellows seal
- Choice of application specific seal assemblies
- Solid ceramic or tungsten carbide plungers
- Choice of bronze or stainless steel suction chamber
- Crank section calculation by 'Finite element method' ensures long working life under continuous load
- Crankshaft supported by 2 bearings and incorporating twin helical speed reducing gears
- Pressurised oil lubrication system with oil cooler/filter

Stationary unit with diesel motor

Length: 126 inch
 Width: 61 inch
 Height: 91 inch
 Weight: approx. 14,330 lbs at 540 HP with full fuel tank

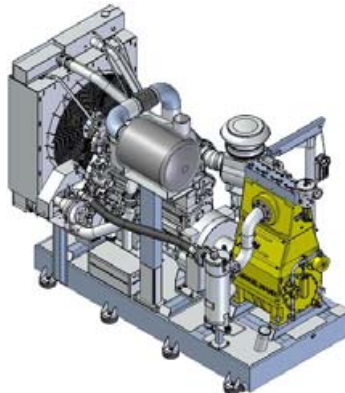

Main dimensions without accessories such as suction line, pressure regulator etc. Detailed dimensional drawings and weights available on request.

HDP 360 series, technical data

Calculated performance parameters

Q [GPM]	Required power rating [HP]					D	r.p.m.	
	270	335	400	470	480		n 1	n 2
Operating pressure [psig]								
11,4 13,5 16,1	36300 30500	43500 37700 31900	43500 38400	43500		28	1500 1500/1800 1800	340 410 490
17,7 21,4 25,6	21800 18100 15200	27600 23200 18900	29700 27600 23200	29700 26800	29000	35	1500 1500/1800 1800	340 410 490
23,5 28,0 33,8	16700 14200 11900	21000 17400 14500	23200 21000 17400	23200 20300	22500	40	1500 1500/1800 1800	340 410 490
30,1 35,9 43,0	13500 11300 9400	16700 14100 11700	18100 16700 14100	18100 16000	17400	45	1500 1500/1800 1800	340 410 490
37,5 44,9 53,9	10900 9100 7500	13600 11500 9400	14500 13600 11500	14500 13300	14200	50	1500 1500/1800 1800	340 410 490
45,9 54,9 65,7	9000 7500 6200	11300 9400 7800	12200 11300 9400	12200 11000	11600	55	1500 1500/1800 1800	340 410 490
55,2 66,0 79,2	7500 6200 5200	9400 7800 6500	10300 9400 7800	10300 9300	9600	60	1500 1500/1800 1800	340 410 490
65,2 78,1 93,7	6400 5400 4500	8100 6700 5700	8700 8100 6700	8700 7800	8100	65	1500 1500/1800 1800	340 410 490
75,8 90,8 108,8	5500 4600 3800	7000 5800 4800	7500 7000 5800	7500 6800	7000	70	1500 1500/1800 1800	340 410 490
99,0 118,5 142,0	4200 3500 2900	5400 4400 3600	5800 5400 4400	5800 5200	5400	80	1500 1500/1800 1800	340 410 490
125,1 150,0 180,0	3300 2800 2300	4200 3500 2900	4500 4200 3500	4500 4100	4200	90	1500 1500/1800 1800	340 410 490
154,6 185,2 222,2	2600 2200 1900	3300 2800 2300	3600 3300 2800	3600 3300		100	1500 1500/1800 1800	340 410 490

Conversion table

Rating 1 hp = 0,746 kW
Op. pressure 1 psi = 0,069 bar
Flow rate 1 gpm = 0,227 m³/h

D = Piston/Plunger dia. [mm]

n1 = Motor/Engine r.p.m.

n2 = Crankshaft r.p.

- Rod force: 45,000 lbf
- Stroke: 2.95 inch
- Mean piston speed at n₂
340 r.p.m. = 2.8 feet/sec
410 r.p.m. = 3.4 feet/sec
490 r.p.m. = 4.0 feet/sec

Typical high pressure pump units



- Stationary unit with diesel motor



- Diesel unit in container

Type designations

Sealing system	D	HDP Type
Hydrodynamic with tungsten carbide plungers	28 - 35	364
Hydrodynamic with solid ceramic plungers	40	363
Labyrinth with solid ceramic plungers	45 - 100	362
Packed sleeves with solid ceramic plungers	45 - 100	367

Hammelmann Corp. 600 Progress Road
Dayton, Ohio 45449
eMail: mail@hammelmann.com • Phone: (001) 937-859-8777
Fax: (001) 937-859-9188
http:// www.hammelmann.com

HAMMELMANN®