

# HDP 196 High pressure, high flow pump



## Compact design

- Optimum space utilisation
- Light weight
- Integral reduction gear

## Adaptability provides installation options

- Reversible pump head
- Central or side suction connection
- Discharge connections on both sides
- Operates at any angle

## Drive end

- Hammelmann standard industrial drive end specifically designed for continuous duty
- Pressurised oil lubrication system
- High quality spheroidal cast iron housing
- Clockwise or anticlockwise rotation

## Water end: suitable for recycled water

Less wear due to :

- High grade solid ceramic plungers
- Wear resistant valve seats
- Low flow velocity over suction and discharge valves
- Packing seal sets within rust resistant stainless steel sleeves
- Slow plunger speed

## Easy servicing

- Reversible valve seats
- Suction and discharge valves use identical components
- Maintenance possible without removal of suction and pressure lines
- All service access from front/above
- Fixed valve housing accessible via light weight cover plates

## Environmentally friendly

- Quiet drive end due to twin helical gears
- Piston rods hermetically sealed by the NBR bellows, no oil leakage

**HAMMELMANN**<sup>®</sup>

## Technical data HDP 196

- Rod force: 66,420 lbf
- Stroke: 2.95 in.
- Mean piston speed at  $n_2$   
460 r.p.m. = 3.7 feet/sec  
550 r.p.m. = 4.5 feet/sec

[GPM]	Pressure [psig]	Power required [HP]	Piston $\varnothing$	$n_1$ [r.p.m.]	$n_2$ [r.p.m.]
101.9	3200	200	70	1500/1800	460
121.4	3000	240	70	1800/2150	550
116.2	2700	200	75	1500/1800	460
141.0	2700	240	75	1800/2150	550
133.3	2300	200	80	1500/1800	460
159.7	2300	240	80	1800/2150	550

### Technical details

Design	Horizontal, vertical, 3 cylinder
Plungers	Solid ceramic
Plunger sealing	Triple packing rings
Crank section sealing	Bellows
Valves	With ancillary sealing for recycled water
Valves, special feature	Reversible
Crank section lubrication	Pressurised circulating
Crankshaft bearings	2 x roller
Drive shaft	Right

### Installation data

Weight incl. lub. oil	1,157 lbs
Mounting hole pattern	14" x 17"
Drive shaft	2.36" dia. x 3.7"
Shaft key	DIN 6885 – A
Permissible lateral force	11,800 lbf
Discharge connection	1 1/4" female
Suction connection	4" i/d, P87 DIN 2631, 2 x 3 "

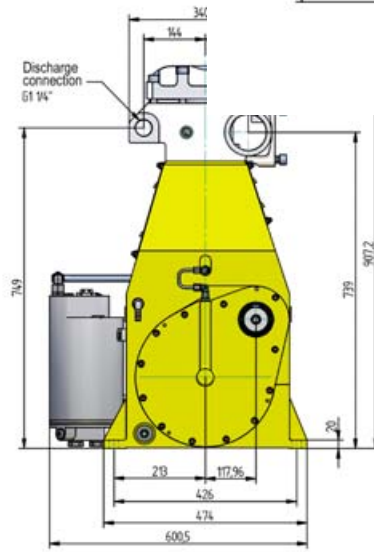
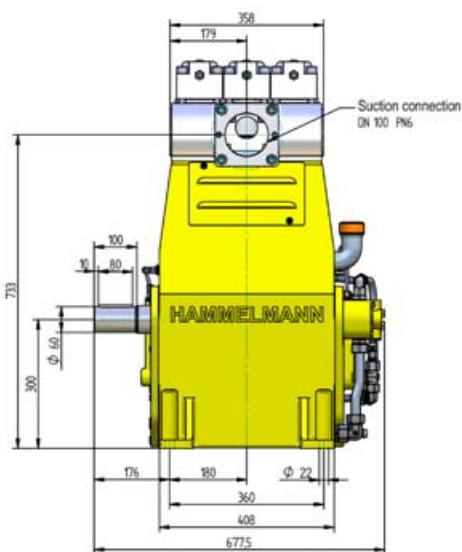
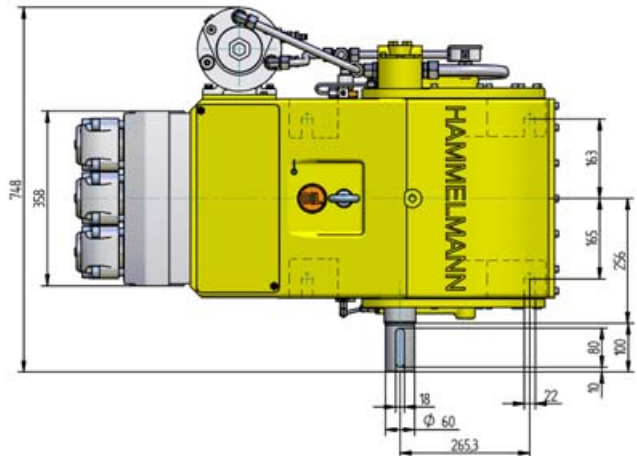
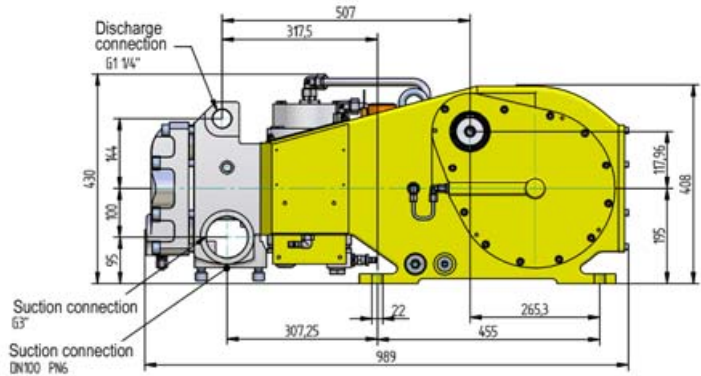

Horizontal design



Vertical design

5/07 © Copyright Hammelmann Maschinenfabrik GmbH, Oelde, Germany. Subject to modification.

**Hammelmann Corp.** 600 Progress Road  
Dayton, Ohio 45449  
eMail: mail@hammelmann.com

Phone (001) 937-859-8777  
Fax: (001) 937-859-9188

http://www.hammelmann.com

**HAMMELMANN®**